



**DOWNEY GLASS**



# DG-300

## FIXED STORE FRONT

- Proudly Made In USA
- Quick lead times
- Get your Quote Today!
- Impact & non-Impact Approved
- Buy Direct !

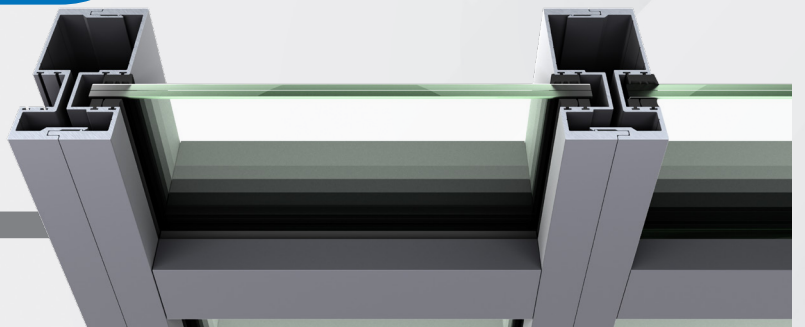
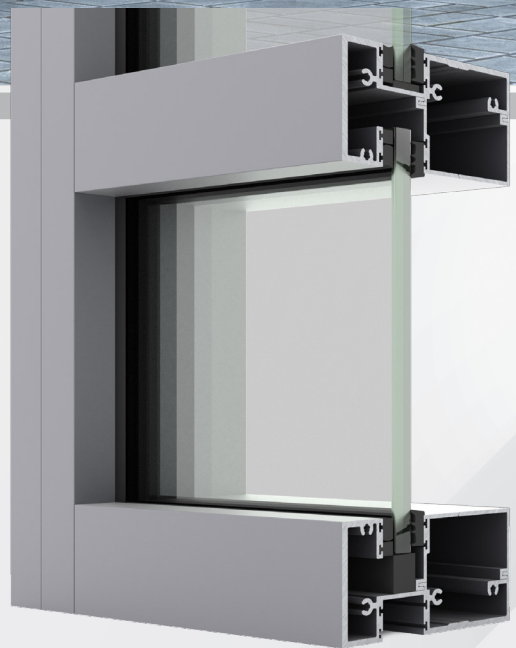

[www.downeyglass.com](http://www.downeyglass.com)

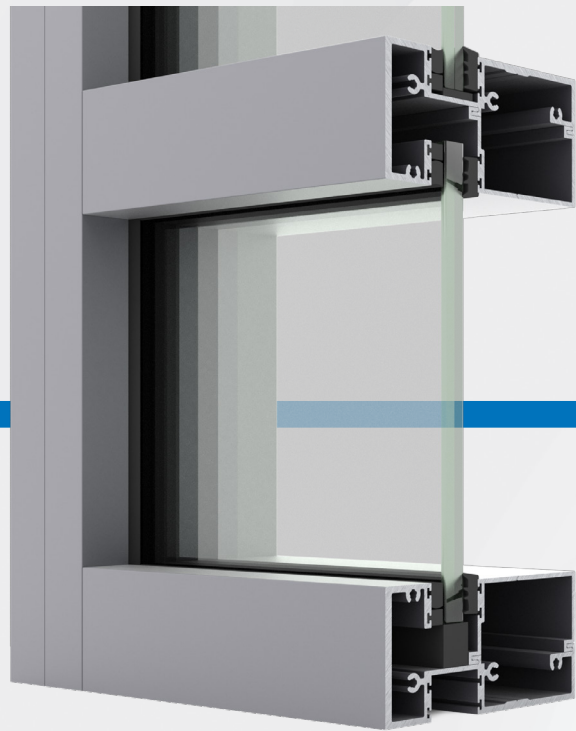

# DG-300

## FIXED STORE FRONT

DG-300 is ideal for expanding the natural light thanks to its significantly compact visible aluminum face width. The system is capable with watertightness performances, which in combination with the high sound reduction make it ideal for the most complex projects.

- Simplicity of use and high functionality
- Flexibility in assembling
- Improved static loads and functionality versus extreme weather conditions
- Ideal in class performances in terms of water tightness and sound reduction

### Glass Colors Options



Clear



Low-e



Bronze



Gray



Super Gray

### Aluminum Colors Options



Clear Anodized



Black

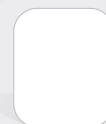

White